



The detailed wagon and van kit

The Prototype

The Diagram G1 covered goods, built 1886-1902, van was one of the earliest vans and was used for perishable loads. Some vans were used as 'Road Vans' or 'Yeast vans' and were allocated to specific towns. The yeast vans probably had four roof ventilators. On delivery of the larger G2 vans from 1902/3 road van and yeast van allocation ceased.

As originally built the G1 van would have had Morton duplex brake gear with the same end brake lever arrangement or possibly single side brake gear. Later construction was fitted with Morton cam brake gear from new. These vans had a long life and it is probable that brake gear would have been updated during the vehicle life.

From the introduction of G2 vans in 1902/3 these vans would have been progressively replaced. It is unlikely that any would have been extant in the later 1930's. Whilst there is a photograph showing a G1 with a roof door there is no evidence that significant numbers, if any, were so fitted in traffic.

This kit represents a grease axle box version and can be built with either the Morton duplex (R & L hand levers) or Morton cam brake arrangements.

These wagons were a common sight in goods yards throughout Scotland and Northern England.

Interested in the North Eastern Railway?

Contact the North Eastern Railway Association.
The Membership Secretary
c/o 8 Prunus Avenue
Willerby
Hull. HU10 6BH

Acknowledgements

51L would like to thank the following for the help and assistance in preparing this model:-
Michael Grocock, Claire and David Williamson

North Eastern Railway London and North Eastern Railway

Diagram G1 Covered goods wagon

from 1886 to 1930's
For OO, EM, P4 and S4

Features: white metal wagon kit

Requires to complete: split spoke wagon 12mm wheels paint, transfers and, couplings

Assembly

Please read these instructions before starting to build your kit. Examine all the parts and familiarise yourself with their assembly. Remove any moulding flash and ensure all parts fit correctly. Drill out 0.5 mm holes for the end handrail loops. These are pot marked on the interior surface of the ends. Check the fit of the wheel bearings and bore out the axleguards/axleboxes if required with a 2mm diameter drill.

Assembly is best carried out using low melt solder or an epoxy resin such as Araldite. Glues like UHU, Multibond or Thixofix can also be used. For small parts use Superglue. A combination of several methods will give best results.

Attach the axle boxes to the sides using the crown plates for alignment. Ensure they are square. Fit the ends to one side, ensuring all is level and square. Having ensured the axles are held securely but not tightly in place by the bearings glue the bearings in place using a Superglue. Fit the other side with the wheels in position

and again check all is square using a flat surface such as a glass sheet. If required gently tweak the wagon to bring all four wheels into contact with the glass surface. Cut the plasticard floor to shape and glue into the wagon interior.

Fit the buffers to the ends with the bolts at the 12 o'clock, 6 o'clock and 9 o'clock positions. Fit hand rails. The hand rail should be attached to the end stanchion using a loop of fine wire, eg 3 amp fuse wire, twisted around the hand rail wire.

Fit the brake shoe/safety loop assembly and the cross bar if building the Morton Cam version. Finally attach the brake levers. If fitting the Morton cam brake lever ensure it is on the brake shoe side of the wagon. Cut the plasticard roof to size, and glue in place.

Finishing

Clean and degrease the model, using white spirit prior to painting. For whitmetal parts use and etching primer, such as Precision Paints PS1. The model should be painted using the livery of your choice. After painting clean the model using a tissue soaked in white spirit. **This is especially important if you are using the "Pow Sides" dry lettering** rather than waterslide or 'Methfix' transfers.

Livery

North Eastern Railway 1898-1903

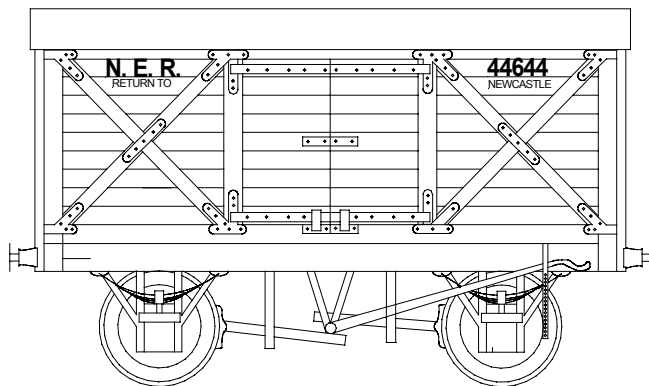

Bodywork, and solebars NER grey
Precision Paint P530
Underframe/brake lever black
Letters and numbers white, shaded black
Pow Sides sheet E264
Town allocation for road and yeast vans only.

North Eastern Railway 1903-1911

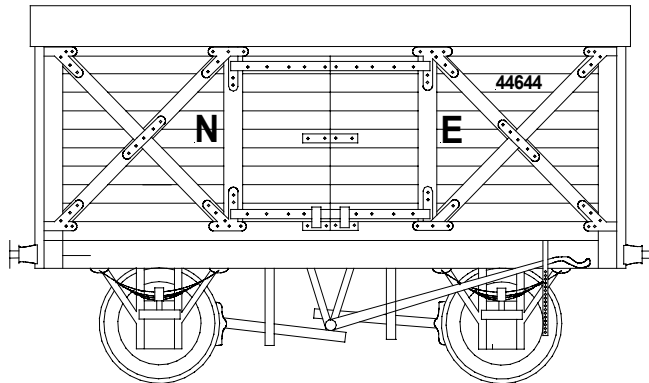

Bodywork, and solebars NER grey
Precision Paint P530
Underframe/brake lever black
Letters and numbers white
Pow Sides sheet E265, Fox FRH4325
Town allocation for road and yeast vans only.

North Eastern Railway 1911-1923

Bodywork, and solebars NER grey Precision Paint
P530
Underframe/brake lever Black
Letters and numbers White Pow Sides sheet E265

London North Eastern Railway 1923-demise

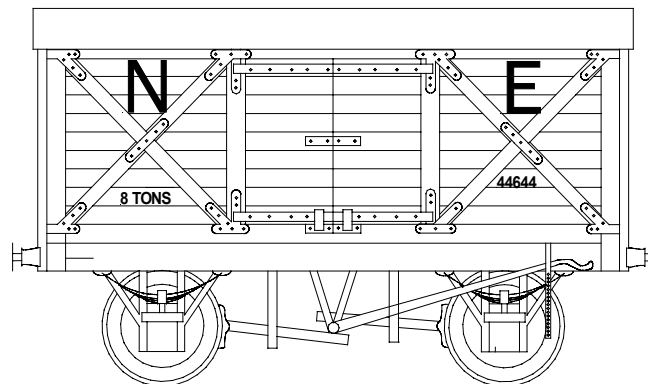

bodywork, and solebars LNER grey
Underframe/brake lever Black
Letters and numbers White
HMRS sheet 12, Modelmaster Sheet 4702,

Sample numbers

Running numbers include:
74287-74336 built 1890-1891, 78013-78036 built 1892-
1892, 78037-78111 built 1892-1893

Allocations included:

Road vans
Darlington: 15272
Leyburn and Thirsk: 15319
Newcastle:
74287 74297, 78048-78062, 74320-43324, 78072-
780074; 78094-78107 probably road vans.
16980, 16987, 19954, 19959,
York: 74307; 78038-78047, probably road vans
Hull: 70863-780071, 74325-74336, 78080-78093, 78108-
78112, probably road vans
Stockton: 74298-74306; 74308-743309, probably road
vans

Yeast vans:

Hull : 4619, 4374, 47734791, 4887, 4942, 7617
West Hartlepool: 44555, 44556, 44557

51L

51L has a wide range of locomotive, carriage and wagon kits for the following railway companies.

GWR and constituents:-
Cambrian, Great Western Railway

LMS and Constituents:-
North Staffordshire, Lancashire & Yorkshire, Glasgow &
South Western, Scottish Joint Stock, Midland Railway

LNER and constituents:-
North British, North Eastern

51L models are available through Wizard Models / 51L.
The most recent assembly instructions will always be
available from the 51L website: www.51l.co.uk

Wizard Models

Wizard models stocks a wide range of components,
paints, transfers and other necessities for the finescale
modeller in OO, EM and P4. A full price list, for 50p +
SAE can be obtained from :-
Wizard Models.

PO Box 225, Macclesfield, Cheshire. SK10 4GB

Tel / Fax: 01625-585312

Email: info@wizardmodels.co.uk

Alternatively see our online server secure shop where
these lists may be downloaded.

www.wizardmodels.co.uk

Version: 1.00

Issued: April 2001