

London & North Western Railway

Birmingham, Liverpool and Manchester Set Trains Non-corridor lavatory stock

D147 Non Corridor 3rd brake
D321 Non Corridor composite

Ten three coach set trains of 57' high roof lavatory stock were built at Wolverton in 1907 on the capital account for seem-fast services between Birmingham, Liverpool and Manchester and via the Staffordshire line. They also worked to destinations as far as rugby, and Llandudno, with even the odd trip as far as Blithely and on the Harborne Branch but were mostly strangers to the Trent valley line and the rest of the system. Certain trains consisted of two sets in tandem, with Birmingham – Manchester and Birmingham–Liverpool sections being divided or combined at Crewe.

A typical diagram (train working schedule) in 1921 was as follows; two sets worked round on alternate days:

	Arrive	Depart
Vauxhall		0120 ECS
Birmingham New Street	0125	0715
Liverpool Lime Street	1038	1210
Llandudno	1500	
Llandudno		1100
Liverpool Lime Street	1509	1910
Birmingham New Street	2150	2210 ECS
Vauxhall	2215	

The ten sets were made up of two BTU's to D321 with a CL to D147 sandwiched between them. Originally the composites were first and second class but after the abolition of second class in 1912 the former second class were demoted to thirds. The BTL compartments were the same generous 6' 6" as in the seconds and 42 wider than the earlier cove roof London- Rugby sets. The first class compartments were an equally luxurious 7' 7". All the carriages were lit by electricity on the Stone's double battery system, and were carried on the standard LNWR underframe with 9' 0" wheel base deep frame bogies at 41' centres.

All ten sets stayed in their original formations until the Grouping at least, and all were repainted in LMS livery and renumbered together except Set 5 which was disbanded in March 1925. From 1922 onwards the Birmingham –Liverpool–Manchester services were worked by 4 carriage inter corridor sets. Accordingly BLM Sets 1-4 were transferred to the Central Wales line thereafter being variously described as Swansea –Shrewsbury, Crewe - Merthyr and Birmingham- Merthyr sets but still numbered 1-4 in the same order. At the same time BLM sets 7- 10 were transferred to the Northampton District, but retaining their identities. These together with BLM set 6, also received an extra carriage about 1923/4 and were re-designated Manchester-Llandudno sets 20, 23, 22, and 24 in that order. Most of the sets seem to have been disbanded and reduced to loose vehicles about 1930.

Numbering details are as follows:

The CL's to D147 were built as numbers 1880-1889 inclusive, renumbered 3919-3928 in the 1910 renumbering scheme; first LMS numbers were 8534-8543, second LMS series 19522-19531. They were marshalled into BLM trains Numbers 8, 6, 5 4, 3, 2, 10, 1, 7, and 9 respectively.

The BTL is to D321 were originally numbered 28, 134, 243, 361, 275, 360, 434, 515, 523, 531, 554, 573, 578, 597, 626, 654, 665, 671, 692, and 724. These were marshalled in pairs in that order in BLM trains numbers 1-10, that is number 28 and 134 in BLM set 1, 243 and 261 in set 2 etc. Post 1910 numbering was 6863, 6895, 6944, 6951, 6956, 6988, 7009, 7043, 7048, 7052, 7066, 7074, 7076, 7082, 7092, 7103, 7107, 7109, 7114 and 7127 in the same order. \First LMS numbers were 6891-6910, second LMS numbers 25551- 25570.

Dates of repainting into LMS livery:

Set 1 3/25, Se2 8/26, Set 3 7/25, Set 4 12/33, Set 5 3/25 (set disbanded), Set 6 11/23 at Derby, Set 7 10/26, Set8 2/27, Set9 2/27, Set 10 10/26.

Withdrawal of the composite carriages took place in between 5/45 and 5/53 (the last being 19529/30) and the brakes between 10/43 and 8/53 (25565 being the last).

Additional comments

These carriages were fitted with Stone's double battery lighting system from new. Loose vehicles were fitted with batteries beneath the floor one each side. Sets of carriages often had batteries in only one or two vehicles with jumper cables between carriages. Usually the brakes were fitted with batteries. After 1913 when the Wolverton single battery lighting system became the LNWR standard it was fitted to any loose vehicles created from sets. A regulator box is include with the model so the Wolverton lighting system can be used if desired. There is no reason to suppose that carriages fitted with the Stone's system were converted to Wolverton pattern after 1914. In common with other LNWR non corridor stock these carriages were not fitted with the Westinghouse brakes. These carriages were fitted with Mansell pattern wheels. The LNWR made a change to steel disc wheels in 1914 but it is unlikely that any carriages were refitted.

References:

An Illustrated History of LNWR Coaches (including West Coast Joint Stock), D Jenkinson P100

A Register of the West Coast Joint Stock , R M Casserley, P A Millard

Selected LNWR Carriages A Detailed Commentary, P A Millard

An Illustrated History of LMS Standard Coaching Stock, R Essery, D Jenkinson, P41

Construction Notes for:

D147 Non-corridor composite
D321 Non corridor 3rd brake

Parts list

Packet 1

Underframe castings

Dynamo 1 off

Vacuum cylinder 2 off

Packet 2

Bogie castings

(9' Deep frame)

Bogie side plates 4 off

Bogie end plate 4 off

Packet 3

Investment castings

King posts (long) 2 off

12BA nuts and bolts x 4

10BA nuts and bolts x 2

Packet 4

Roof castings

Torpedo vents, 20 off

Brake side lights (321 only),
3 off

Duck boards x2

Lavatory water tank fillers,
147 x7; 321 x3

Packet 5

Set sprung round buffers

Interior items

Polystyrene strip 0.030" x1

Polystyrene strip 0.020 x 2

Glazing strip, 2 off

Seating

Roof materials

Aluminium roof

Microstrip, 2 lengths

Miscellaneous

0.5mm wire, x3

0.7mm wire, x0.5

You will find that there are a number of spare components to allow for the inevitable dropping of small items.

Underframe

Cut or snip out floor (C1) from stepboards, place the stepboards carefully to one side. The floor has six holes in it, four at the corners and two along the centre line for the bogies. Taking the 4 corner holes bore to accommodate the 12 BA bolts provided. Then drill out the 2 bogie centre pilot holes to accommodate 10 BA bolts provided. Do not fold up the vee hangers yet.

Punch the rivet detail on the solebars to represent the rivets. Do this on a firm surface, taking care not to distort the floor. Fold along the half etched lines to 90 degrees form the floor and solebar. Taking the full length stepboards, tin the inner face of one board and then fold through 180 degrees with the half etched tab to the inside. Supporting the stepboard in a vice run your soldering iron along the edge. Start at the centre of the board and work out to the end. Repeat this process for each full length stepboard and for lower stepboards. If using glue, apply to the inner faces and fold. The full length stepboards should now be fitted to the floor leaving 1mm of solebar showing below. Now fit the lost wax castings of king posts, 35mm apart, thread wire through the holes in the king posts to form the trussing. Using etched droppers fit lower stepboards.

The Battery Box and Underframe Fittings

First of all drill out the pilot holes in the box top and bottom plates (part 10) to accept 0.4mm wire. Then carefully scribe a centre line on what will be the outer face (part9) of the battery box, use this as guide when lining up with the base. Fold the sides to 90 degrees, then place in position on base plate with the scribed centre line in line with the centre hole. Repeat this for the top plate and thread the wire through the holes. Solder or glue in place between the king posts. For carriages with the Wolverton electric system, one battery box is needed. Opposite to the battery fix the cast regulator box. The regulator box should be fitted with the angled face facing outwards just below the solebar. See P21 Jenkinson for a photograph of the installation. If the carriage is fitted with Stones electric system place a battery box between each king post. Note most if not all D147 and D321 carriages were fitted with Stone's lighting system.

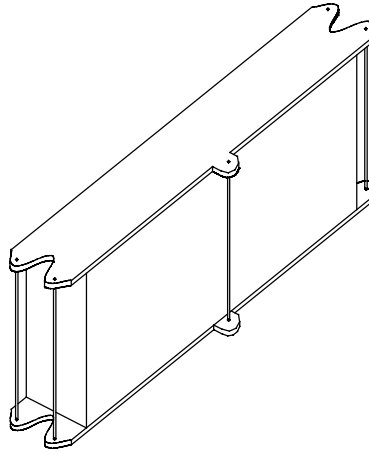

The cast dynamo should be fitted under a third class section of the carriage never under the brake compartment or a 'superior class'. Position the dynamo some 16mm (4') from the adjacent bogie axle centre line and 3mm from the carriage centre line. The dynamo may require a triangular packing piece to ensure it is vertical and the pulley slightly lower than the wheel axle.

Fold the vee hangers and thread wire through the holes and through etched brake linkage components, the hole in the floor next to the vee hangers gives the position for the cast vacuum brake cylinder

Bogies

Clean any flash from bogie side frames and transom castings. Cut brass stretchers and radius plates out from the etch. Drill out the pilot holes in the stretchers to accommodate 10 BA bolt, which you should now solder into place on the carriage floor in readiness to accept the bogie. Drill out the pre-marked axle centres on the cast side frames. Solder the two radius plates in the slots on the brass stretcher. Then solder the transom ends in place. Solder one side frame to the brass stretcher, fit bearings and wheels to choice and solder the other cast side in place.

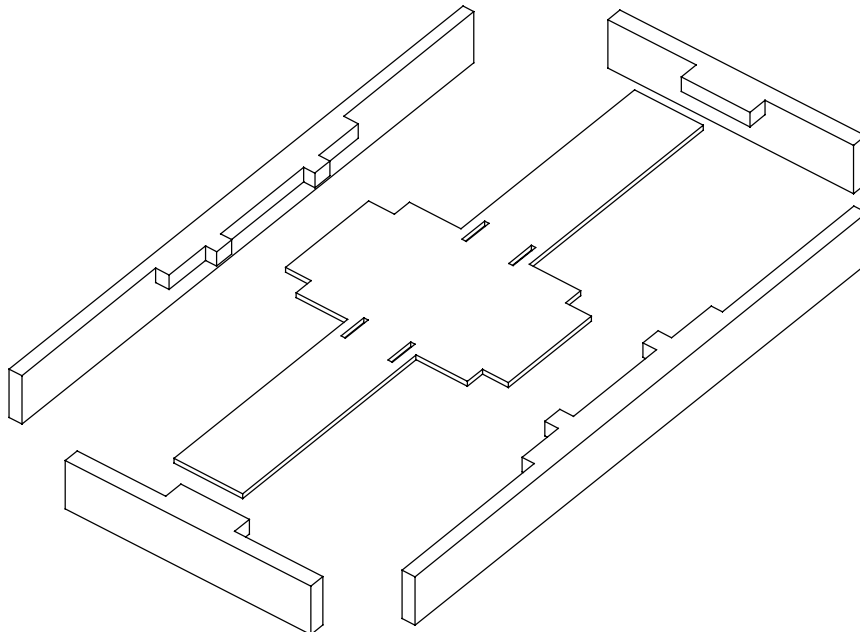

Carriage Sides

Carefully remove carriage side from fret. Take care to form the tumblehome curve below the waistline by forming it around a half inch tube or a suitably profiled piece of wooden skirting board, the amount of curve is shown by the carriage end.

Now carefully remove the etched droplights with integral hinges from the etch. Bend hinges as shown in the diagram and locate in the pre-etched holes in the carriage sides.

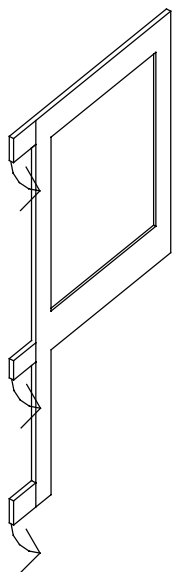

Carriage Ends

Carefully remove carriage ends parts 3 and 4, part 5, part 5a and both component parts number 7. Drill out the pilot holes for the end handrails and grab rails on each end. Fold part 5 to form the steps by folding each to 90 degrees and the wings to support the sides by folding each to 90 degrees. Locate the steps by fitting from the inner face of the end (3) with pre-etched slots. Secure with solder or glue. Fold part 5a to form the wings to support the sides at the other end of the carriage by folding each to 90 degrees. Secure with solder or glue, avoid covering up the holes you have already prepared for the grab rails.

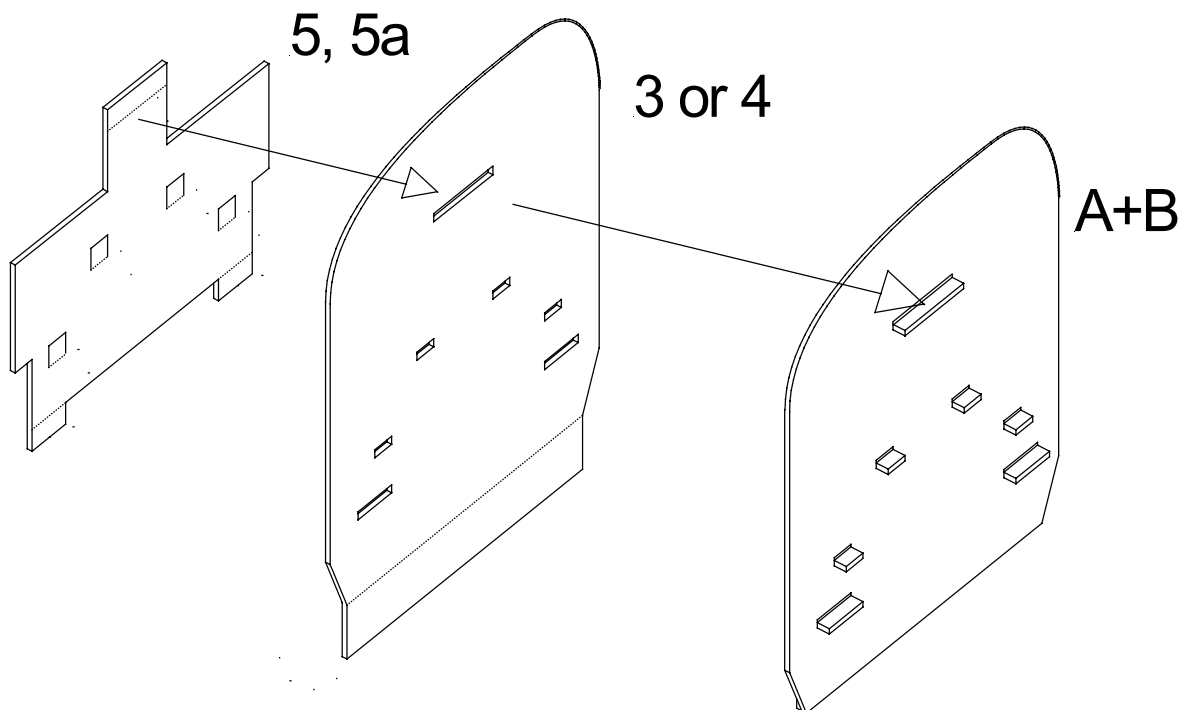

Before folding parts 7 mark centres to line up the two holes at each end of the carriage floor, drill to accommodate 10 BA bolts, now fold up part 7 to make a three sided box. Solder parts 7 to the inner faces of each end, leaving enough space to fit the styrene floor, please see diagram. Solder or glue the carriage sides to the ends, ensure squareness, tack solder first then when satisfied run solder into each corner joint. Fit handrails and grab rails from wire to the ends.

Carefully cut door and window ventilators, fit short vents in the panel over each door and the longer vents over the corridor windows.

Fit door furniture after painting.

Trial fit the floor to body, adjust if required, solder 10 BA bolts in place on upper faces of each part 7.

The Roof

Cut the aluminium roof to length trim the corners of the flange to clear the ends.

Mark the roof centre line and positions of all roof detail. Torpedo vents should be fitted two per compartment a scale three feet apart on the roof centre line. A ventilator is required for each toilet, on toplight carriages the ventilator again fitted on roof centre line but on earlier traditionally paneled carriages it was offset 6 inches towards the compartment side.

Cast roof duckboards should be fitted on the centre line at each end.

Roof grab rails should be fitted at the steps end either side of the duckboard.

Glue the roof on to the body of the carriage.

Interior Fittings

The styrene floor must be cut to length to fit between each headstock and to have a width of 34mm. And two holes drilled at each end to accommodate 10 BA bolts. Use the remaining styrene to make the compartment partitions.

Using the bulkheads to give the profile of the compartment partitions cut the required number from the styrene and glue in place. Cut the seat moulding to fit each compartment and glue in place.

Finishing

Clean and degrease your model, using white spirit before painting. For etched brass and white metal models an etching primer, such as Precision Paints PS1, is essential. Follow the manufacturers instructions bearing in mind that only a light covering is required. The model should then be painted using the livery of your choice.

After painting, clean your model using a tissue soaked in white spirit. Letter your carriage to suit your chosen period. Suitable lettering is supplied by the HMRS and paint by Precision Paint for the LNWR, LMS and BR periods. It will be appreciated that some carriages, those at the end of their useful life, would not have been repainted by their new owners and earlier liveries could have been around for many years. The London and North Western Railway used a painting cycle of 5 to 6 years and so LNWR livery survived to around 1930. The following information is offered as a guide and modelers are advised to obtain suitable photographs and consult the suggested references listed above.

London and North Western Railway Carriage livery

The LNWR livery is often referred to as 'plum and spilt milk'. The lower panels and mouldings were a 'carmine lake' colour. Usually the vents were also lake. The upper panels were a shade of white created by the addition of a small amount of blue to the white base colour and the yellow effect of varnish. The carriage ends were painted chocolate not lake and the underframe and running gear black. Fixed window frame mouldings were usually indian red and the door and window drop lights varnished natural wood. On the rounds of the raised mouldings a gold coloured line (1/2") edged with a 1/8th white was applied. When applied adjacent to the carmine lake panel this white line was both sides of the gold. In contrast the white line was only on one side where the adjacent panel was white. The gold colour was made from a mixture of lemon and orange. A white line 1/8th was applied to the edges of the doors. The brake van double doors were given a slate waste panel for the marking of destinations.

The roofs were generally painted white but degenerated to a grey colour in service.

The interior should be painted dark red for third class seats and darkish green for first class seats, wood brown for the compartment divisions and guards area.

We suggest the following Precision Paints:

Carriage carmine lake P379

Carriage 'white' P380

Lining tan P381

London and North Western railway carriage lettering and numbering

This was applied in the gold colour used for lining, Sans Serif style and edged in black. Class designation and other wording was applied to the waist panels of the doors and running numbers located just above the waste rail. Transfer crests were applied to the lower panels usually one or two to a carriage. Often monogrammed initials were also used. Suitable lettering materials are supplied by the HMRS sheet number 16.

London Midland and Scottish Carriage livery

Suitable lettering materials are supplied by the HMRS, sheet number 2 and paint by Precision Paint.

The London Midland and Scottish carriage livery was highly standardised and it is possible to be fairly sure what the livery was like for a given period. In general up to the war years carriages were painted every six or seven years. Carriages were painted crimson lake, a shade very similar to the Midland Railway shade. Until 1936 both the ends and sides were painted crimson lake but from that date the ends were painted black with the exception of driving ends of motor carriages which remained crimson lake. Detail work on the ends, steps, pipework etc was painted black. In 1946 the LMS changed the name to maroon although it is doubtful if any change in colour was discernible. However it does seem possible that the colour had become slightly darker over the years. Roofs were generally painted in the Midland style of light grey between the rain strips and black between the rain strips and cantrail. From 1933 onwards to outbreak of war the roof was specified to be a metallic aluminium type finish. The roofs quickly became dirty in service and more often than not were a muddy grey colour.

London Midland and Scottish lettering and lining

Prior to the close of 1934 early 1934 all carriages were lined in Midland style. Raised beading was painted black and edged with a 3/8th gold for gangwayed stock or 3/8th pale yellow for non-gangwayed stock. These lines were edged each side with a 1/16th vermilion line. All three colours appeared on the beading and not the body panels. In all cases the lining followed the outline of the beading. Carriage ends were not lined and beading if present painted black as per the previous Midland practice.

From 1934 onwards a simplified lining system was adopted. This consisted of a 1/2" yellow line just below the cant rail, and a similar line above the tops of the windows. In addition just below the windows two 1/2" yellow lines separated by a 1" wide black line. The yellow lining had a darker shade than previously. During the Second World War lining was discontinued on the few carriages to be repainted. General touching up was the norm during this period. From 1946 lining was readopted and the yellow changed to straw.

Lettering such as LMS etc was applied to the carriage sides in serif characters 4" high. The colour was gold until 1934/5 when chrome yellow was used. The lettering was shaded in pinkish white to the left blending to dark red/brown below the characters, in turn the shading was shadow shaded to the right and below in black. Some pre-group carriages with shallow depth waist panels had 3" letting. The class type was marked on the doors 8" high rendered in gold. The LMS emblem was not used on non corridor stock and was near to the centre of the carriage. Insignia were generally placed as near to the centre of the carriage as possible in the waist panel. We suggest the use of HMRS sheet 1 for the early period, gold lining; or sheet 2 for the later period.

The following Precision Paints are suggested:

Crimson lake	P30
Carriage roof grey	P40
Carriage roof aluminium	P41
Lining gold (gangwayed stock)	P35
Lining yellow	P36
Vermilion	P37

British Rail

Those gangwayed carriages which were repainted by BR were painted crimson and cream (blood and custard) and were lined. It is suggested that suitable photographs are examined as only some stock was repainted at all!

We suggest the following Precision Paints:

Carriage crimson red	P116
Carriage cream	P117
Roof grey	P131
Maroon	P108

Wizard Models 51L

PO Box 225 ,
Macclesfield
Cheshire,
SK10 4GB
Tel and fax 01625 532944
email: info @51L.co.uk

Version: 1.0
Issued: May 2004

www.51L.co.uk