

**Caledonian Railway
London Midland and Scottish
British Rail**

**Diagram 67 Covered Goods Wagon
Outside framed
1910 to 1950's**

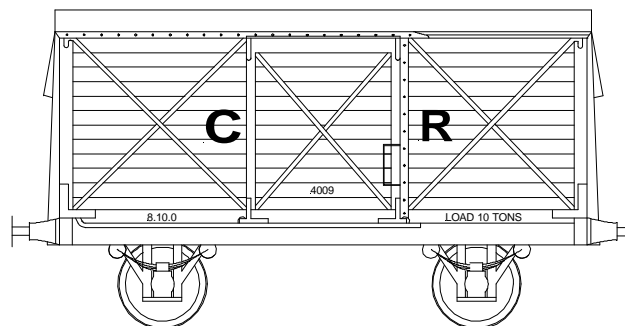

For OO, EM and 18.83mm

The Prototype

First built in around 1910, this van would have formed a substantial part of the Caledonian Railway's van fleet at Grouping in 1923. A modern design, this van was quite long lived and examples lasted until British Rail in the early 50's. The design was perpetuated into a vacuum fitted version.

Whilst the numbers built is unknown it is thought to have been many hundreds. A common sight in goods yards in industrial Scotland and the northern counties of England noticeably the north West Coast route.

References:

"British Goods Wagons from 1887 to the present day"
by Essery, Rowland & Steel

Interested in the Caledonian Railway?

Contact the Caledonian Railway Association.
The Membership Secretary
Mr F Landery
45 Sycamore Drive
Hamilton
ML3 7HF

Requires to complete:

split spoke wagon 12mm wheels; paint; couplings; transfers

Assembly

Please read these instructions before starting to build your model. Examine all the parts and familiarise yourself with their assembly. Remove any moulding flash and ensure all parts fit correctly. We suggest wet fine emery paper (1200 grit) may be useful to clean up any flash marks.

Assembly is best carried out using low melt solder or an epoxy resin such as Araldite. Glues like UHU, Multibond or Thixofix can also be used. For small parts use Superglue. To obtain the best results a combination of several techniques will be needed.

Carry out a dummy run prior to assembling the parts. Check the fit of the wheel bearings in the axleboxes and bore as required. Fix both ends to one side checking that all is square. Fit the second side with

wheel bearings and wheel sets in place. Ensure the wheels are firmly supported yet turn freely. If necessary bore or pack bearings in the axle box as required. When satisfied fix the second side in place. Again, check all is level and square. If not a gentle tweak will bring all four wheels into contact with a flat surface such as a glass sheet.

Bore the cross shaft hole (0.7mm) in the brake gear casting and fit the brake shoe assembly in place. Cut a length of 0.7mm brass wire to form the cross shaft and fit between the v-irons, secure in place. Fix both brake levers in place, the cam lever should be at the brake shoe side of the wagon. Attach brake safety loop to the brake shoes. These U shaped loops are formed from flat wire supplied and should be adjacent to the brake shoe. Exact position varies from wagon to wagon.

Fix the buffers in place ensuring the rib faces the outside of the wagon. Bore out the holes in the doors to 0.5mm to take the door handles. These should be shaped following the drawing. Fix into place. Trim the supplied roof to shape and attach. Allow slight overhang at either end.

Finishing

Clean and degrease the model, using white spirit prior to painting. For white metal parts use and etching primer, such as Precision Paints PS1. The model should be painted using the livery of your choice. After painting clean the model using a tissue soaked in white spirit. **This is especially important if you are dry lettering** such as, that available from the Caledonian Railway Association **rather** than waterslide or 'Methfix' transfers.

Livery

Caledonian Railway c1900-1923

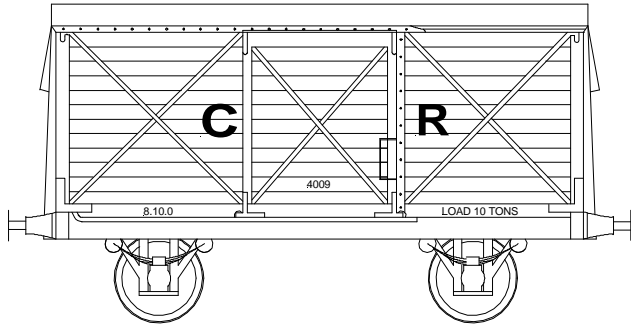

Bodywork, solebars and buffer housing
Red oxide, Precision Paint P436
Underframe/brake lever, solebar iron work black
Roof white weathering to grey/black
Letters and numbers white
HMRS sheet 20, Caledonian Railway Association sheet.

London Midland and Scottish Railway 1923-1937

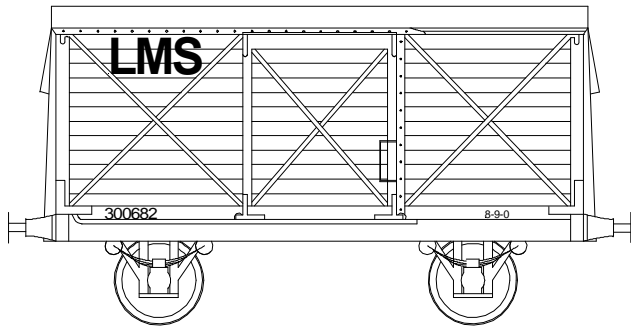

Bodywork and solebars grey Precision Paint P38
Iron work below solebars black, Precision P975
Roof white weathering to grey/black
Lettering white HMRS sheet 6, Modelmaster 4701

London Midland and Scottish Railway 1937- 1948

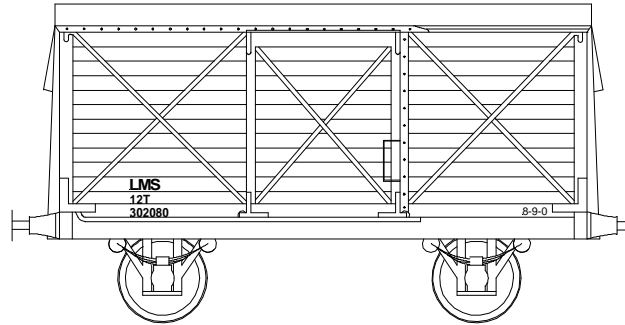

Body bauxite Precision Paint P39
Iron work beneath solebars black Precision Paint P975
Roof white weathering to grey/black lettering white
HMRS sheet 6, Modelmaster sheet 4701

British Rail 1948-demise

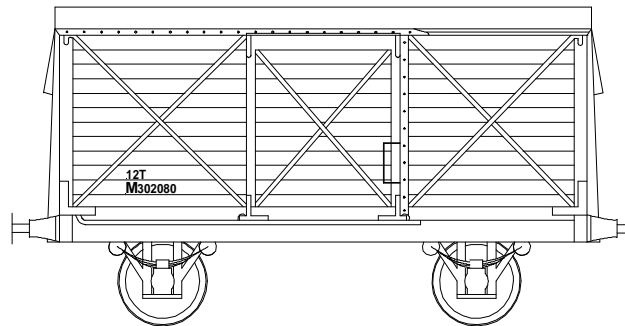

Light grey, or bare timber with lettering on a black patch. Precision Paint P126

Lettering and numbers white
HMRS sheet 25, Modelmaster sheet 4619

It will be appreciated that many wagons would not have been repainted by the LMS or BR and would remain in a weathered group or even pre-group livery or by that time weathered timber!

Acknowledgements

51L would like to thank members of the Caledonian Railway Association for their help and assistance in preparing this model.

Sample Numbers

These are known to have included: 682, 2080, 4009, 4543, 7455, 73611

51L

51L has a wide range of Locomotive, carriage and wagon kits for the following railway companies:

GWR and constituents:-

Cambrian Railway

LMS and Constituents:-

North Staffordshire, Lancashire & Yorkshire, Glasgow & South Western, Highland Railway, Midland Railway

LNER and constituents:-

North British, North Eastern

51L models are available through Wizard Models / 51L.

The current version of these assembly instructions will be available on the 51L website: www.51l.co.uk.

For further help or information please email:

info@51l.co.uk

Wizard Models

Wizard models stocks a wide range of components, paints, transfers and other necessities for the finescale modeller in OO, EM and 18.83mm. A full price list, for 50p + SAE can be obtained from :-

Wizard Models

PO Box 225, Macclesfield, Cheshire. SK10 4GB

Tel / Fax: 01625-585312

Or from: www.wizardmodels.co.uk

More recent versions of this instruction sheet may be available on our web site.

Version: 2.00

Issued: April 2002